

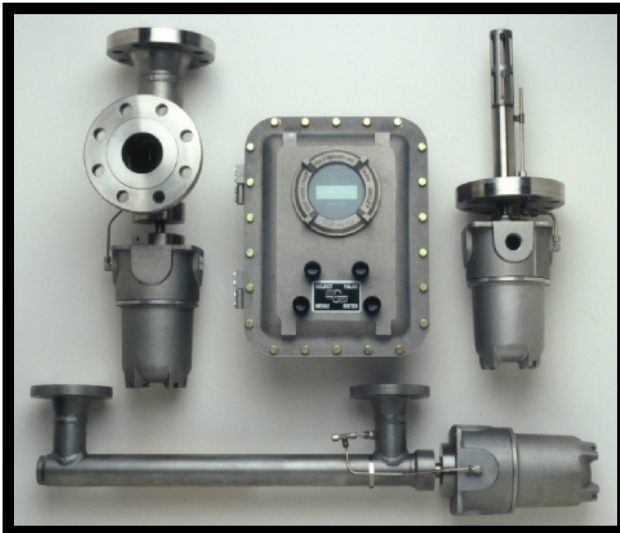

## *Family of Water Cut Analyzers*



- **Low Range (0-4%, 0-10%, 0-20%)**
- **Mid Range (0 to Inversion)**
- **Full Range (0-100%)**
- **High Range (80-100%)**
- **Flow-Through Analyzers in 1” To 4” Pipe Sizes**
- **Insertion Analyzers for Installation In Pipes 6” and Larger**
- **Three Styles of Flow-Through Configurations**

- 
- **CSA, FM, ATEX & PED (Optional)**
  - **RTD Temperature Measurement**
  - **Configurable Current Loop & Alarm Outputs**
  - **True Net Oil and Net Water (With Flow Input)**
  - **Modbus RTU, HART Available**
  - **24 VDC, 120 VAC and 230 VAC**
  - **Density Correction Available**
  - **New Family of Electronics Provides Data Logging & Touch Screen Capabilities Including Graphics**
  - **Enhanced Electronics Can Replace Flow Computers In Fiscal Systems**

This family of Water Cut Analyzers was developed specifically for use in the oil industry. The Low Range Analyzer is typically used for custody transfer or pipelines. The Full Range analyzer is used for emulsion control in tanks, for control of high water cut situations, and for interface control. Flexibility for the user is provided for through various configurations including an insertion unit.

Phase Dynamics' Full and Low Range Analyzers offer the most accurate measurement possible. The Low Range Analyzer has been used on custody transfer pipeline installations by all major oil companies. Phase Dynamics utilizes the unique, patented, "Oscillator Load Pull" microwave technology which provides for this outstanding capability. No other technology can compete with its benefits.

All functions of the analyzers can be accessed through the front panel by four push button switches. The LCD display indicates the measurement value as well as temperature, net oil, net water, and phase of the emulsion (full range only). Full digital Modbus RTU access to the information is standard. Electronics are available in NEMA 4 or explosion proof enclosures

## Water Cut Analyzer Operational Specifications

PARAMETER	Low Range		Mid Range	Full Range	High Range
RANGE	0-4% & 0-10%	0-20%	0-Inversion	0-100%	80-100%
UNCERTAINTY*	+/- 0.04% (0-4%) +/-0.1% (4-10%)	+/- 0.2% Oil Phase Only	+/- 0.5% Oil Phase Only	Oil Phase +/- 0.5% Water Phase +/- 1%	+/- 0.6% Water Phase Only
REPEATABILITY	+/- 0.02%	+/- 0.1%	+/- 0.1%	Oil Phase +/- 0.1% Water Phase +/- 0.5	Water Phase +/- 0.3%
RESOLUTION	0.01%	0.1%	0.1%	0.1%	0.1%
FLUID TEMPERATURE	60 - 160° F	60 - 160° F	60 - 160° F	60 - 160° F	60 - 160° F
HIGH TEMP. VERSION	60 - 220° F	60 - 220° F	100 - 600° F	100 - 600° F	100 - 600° F
SALINITY	Not Applicable	Not Applicable	Not Applicable	0.5% - 8% Water $\Phi$ Oil $\Phi$ Not a Factor	0.5% - 8% Water $\Phi$

\* All percentages are expressed as absolute water content percentages within a 2 Sigma deviation (95% Confidence).

### General System Specifications

#### Measurement Section:

##### Pressure Ratings:

Flange Sizes up to ANSI 1,500; Raised Face Flanges Standard; RTJ and Flat Face Optional

##### Construction:

316/316L Standard; Other Materials Available; Designed and Fabricated per ASME B31.3 & ASME IX; Full Material Certifications Optional

##### Certifications:

Class 1, Div. 1, Groups C&D;  
EEx d IIB T5 78°C - IP66 (Optional)

##### Process Connections:

Low Range Analyzers: 1, 2, 3, 4 inch Flanges and Insertion Type in 3" Flange  
All Other Analyzers: 2, 3, 4 inch Flanges Insertion in 3" Flange

#### Electronics Enclosures:

##### 3 or 6 Conduit Entry Explosion Proof Enclosures:

17.4 H x 14.0 W x 9.9 D inches; 59 lbs., NEMA 4, 7, 9 & 4X;  
Class 1, Div. 1, Groups C & D; EEx d IIB T5 89°C - IP66 (Optional); [See Figure 1](#)

##### 8 Conduit Entry Explosion Proof Enclosures:

17.4 H x 14.0 W x 11.9 D inches; 71 lbs., NEMA 4, 7, 9 & 4X;  
Class 1, Div. 1, Groups C & D; EEx d IIB T5 89°C - IP66 (Optional); [See Figure 1](#)

##### Rain and Dust Tight Fiberglass Enclosure:

16.3 H x 10.5 W x 7.9 D inches; 17 lbs., NEMA 4; [See Figure 2](#)

#### Alarms:

Stand-Alone Integral Transmitter: Does not include any relays

##### Any Electronics Enclosure:

Includes Dry Contact Closure Rated 1 Amp, 120 VAC, Field Definable Setpoint  
System Error Dry Contact, NO or NC Rated 1 Amp, 120 VA

#### Process/Ambient Temperatures:

##### Fluid Temperature Compensation:

Automatic with Built-in RTD Temperature Probe

##### Ambient Temperature Ranges:

Measurement Section: -40° to +120° F  
Electronics: +32° to +120° F; Sun Shade Recommended  
- 40° to +120° F (With Optional Heater)

##### Fluid Temperatures:

Standard 60° to 160° F  
Optional 60° to 220° F  
Optional 100° to 400° F  
Optional 100° to 600° F  
Lower Temperatures Optional

#### Cables:

##### Between Standard Analyzer Measurement Section and Electronics Enclosure:

Dedicated 19 Conductor, 22 AWG, 3 Twisted Pairs, 1/2" Diameter, Special Factory installed Military Connector (armored cable not available). 150 feet Maximum Length between Electronics and Measurement Section; typically in Conduit. A 14 gauge ground wire MUST be connected between measurement section and main electronics to assure proper operation and meet FM requirements.

##### Between Stand-Alone Analyzer and Optional Electronics:

Optional 9 Conductor Composite Cable (2 Twisted Pairs 24 AWG, 1 Twisted Pair 20 AWG, 3 Conductors 18 AWG), PVC Jacket (armored cable available). Nominal Diameter 9.68 mm (fits 1/2" conduit). 400 feet Maximum Length.

#### Certifications:

Explosion Proof Enclosures; CSA, FM, ATEX/PED (Optional)  
NEMA4X Fiberglass Enclosure CSA Approved (Optional)

# Family of Water Cut Analyzers

## 1.) Standard Analyzer

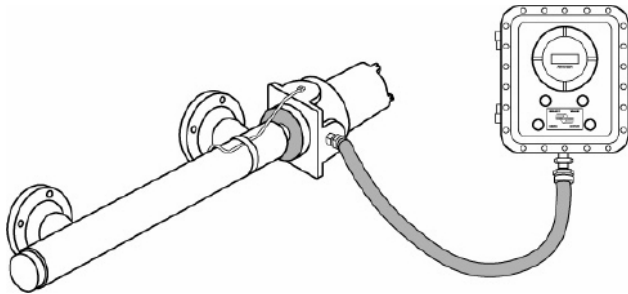

### A.) With Standard External Electronics

- When user requires local display in Zone 1 and 2 explosive area.
- Maximum distance between sensor and transmitter is 150 feet.
- Can be powered by 110 VAC 60 Hz, 230 VDC 50 Hz, or 24 VDC.
- 4 line 20 character LCD Display.
- Analyzer does not have data logging capabilities.
- Standard outputs are:
  - One (1) analog 4-20 mA, One (1) digital Modbus RTU RS-485; HART optional.

### B.) With Enhanced External Electronics

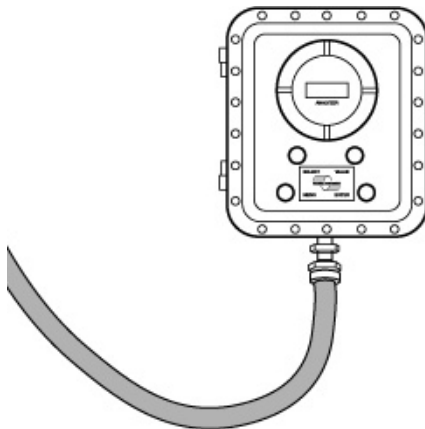

- Data Logging User Selectable up to 65 Days.
- Four (4) Modbus RTU RS-485 Ports, and HART with 275/375/AMS Support. One (1) Analog Input, One (1) Frequency/Pulse Input.
- Updated Computer with Surface Mount Electronics.
- Full Capability as a Flow Computer.
- Standard 4 Line 20 Character LCD Display.
- Optional Color Graphics Display
  - Data Trending Graphs
  - Error Event Logging
  - Touch Screen Entry.

### C.) With Expanded External Electronics

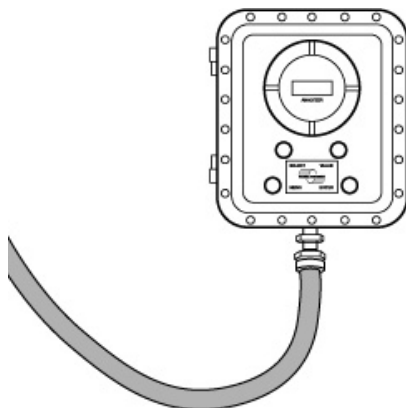

- Enhanced Electronics Capabilities Plus Multiple Analog Inputs and Outputs.
- Provides Five (5) Configurable 4-20 mA Inputs, Three (3) Frequency/Pulse Inputs, Five (5) configurable 4-20 mA Outputs.
- Full Capability as a Flow Computer.
- Standard 4 Line 20 Character LCD Display.
- Optional Color Graphics Display
  - Data Trending Graphs
  - Error Event Logging
  - Touch Screen Entry.

# Family of Water Cut Analyzers

## 2.) Stand-Alone Analyzer

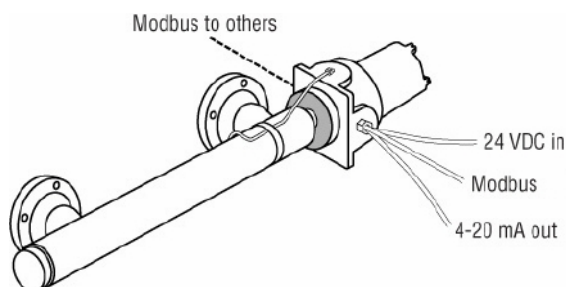

### A.) With Integral Transmitter at Measurement Section - No External Electronics

- When user does not require local display.
  - Wiring from Analyzer to control room up to 4,000 feet (with standard twisted pair wire).
  - Powered by 24 VDC Only.
  - Especially suitable for multi-analyzer systems; up to 32 Analyzers can be connected in series on twisted pair wire.
- All functions of the Analyzer can be accessed via a handheld or the PC configuration tool.
  - Standard Outputs: HART 4-20 mA and Modbus RTU RS-485.
  - Capable of 65-day data logging (FLASH based memory).

### B.) With Optional Enhanced Electronics

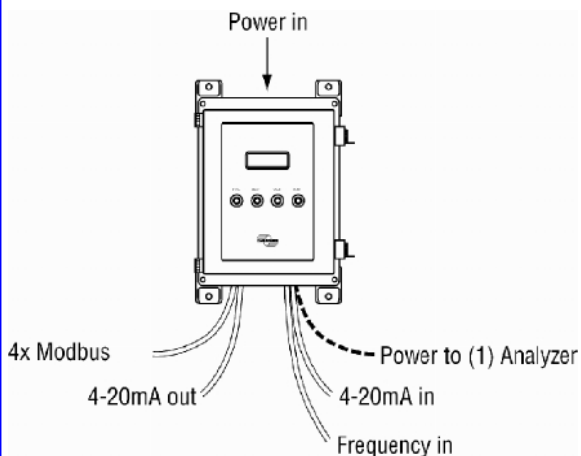

- When user prefers local (explosion proof) or control room (NEMA 4) display.
- Data Logging User Selectable up to 65 Days.
- Four (4) Modbus RTU RS-485 Ports, HART with 275/375/AMS Support. One (1) Analog Input, One (1) Frequency/Pulse Input.
- Updated Computer With Surface Mount Electronics.
- Standard 4 Line 20 Character LCD Display.
- Optional Color Graphics Display
  - Data Trending Graphs, Error Event Logging, Touch Screen Entry.

### C.) With Optional Expanded Electronics

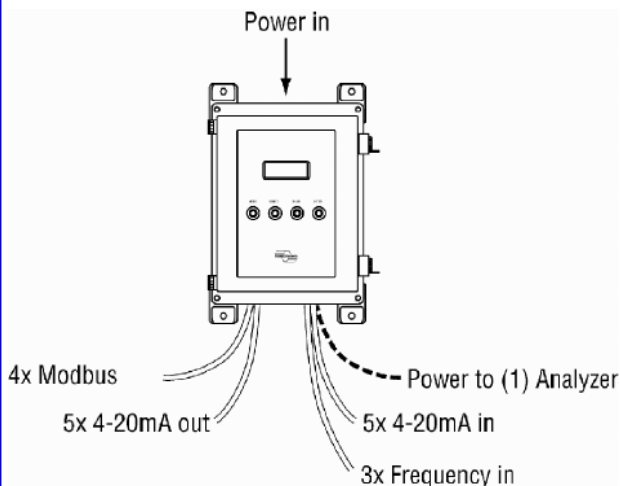

- Enhanced Electronics Capabilities Plus Multiple Analog Inputs and Outputs.
- Provides Five (5) Configurable 4-20 mA Inputs, Three (3) Frequency/Pulse Inputs, Five (5) configurable 4-20 mA Outputs.
- Full Capability as a Flow Computer.
- Standard 4 Line 20 Character LCD Display.
- Optional Color Graphics Display
  - Data Trending Graphs, Error Event Logging, Touch Screen Entry.

## Power & Electronics Specifications

### Stand-Alone Analyzer:

Power Requirements:  
 18-28 VDC  
 25 Watts Typical, 50 Watts Maximum

Outputs:  
 Analog: 4-20mA, 16 bit D-to-A Conversion  
 Digital: RS-485 Modbus RTU  
 HART (Optional)

### Standard Analyzer:

Power Requirements:  
 100-130 VAC 60 Hz (50 Hz Optional)  
 200-260 VAC 50-60 Hz (Optional)  
 18-28 VDC (Optional)  
 25 Watts Typical, 50 Watts Maximum

Outputs:  
 Analog: Field Selectable 0-20mA or 4-20ma, 12 bit D-to-A Conversion  
 Digital: Modbus RTU RS-485 Standard, RS-485 ASCII (Optional), RS-422 ASCII (Optional), HART (Optional)

Inputs:  
 Frequency: Voltage or Magnetic Pickup Pulse (3mV to 15V max.) with Field Selectable Definition  
 Analog: 0-20 or 4-20 mA with Field Selectable Definition

### Enhanced Electronics:

Power Requirements:  
 18-28 VDC  
 120-230 VAC 50-60 Hz (Optional)  
 25 Watts Typical, 50 Watts Maximum

Outputs:  
 Analog: 4-20mA, 16 bit D-to-A Conversion  
 Digital: Four RS-485 Modbus RTU, HART

Inputs:  
 Frequency: Voltage or Magnetic Pickup Pulse (3mV to 15V max.) with Field Selectable Definition  
 Analog: 0-20 or 4-20 mA, 16 bit A-to-D Conversion with Field Selectable Definition

### Expanded Electronics:

Power Requirements:  
 18-28 VDC  
 120-230 VAC 50-60 Hz (Optional)  
 25 Watts Typical, 50 Watts Maximum

Outputs:  
 Analog: Five (5) 4-20mA, 16 bit D-to-A Conversion  
 Digital: Four RS-485 Modbus RTU, HART

Inputs:  
 Frequency: Voltage or Magnetic Pickup Pulse (3mV to 15V max.) with Field Selectable Definition  
 Analog: Five (5) 4-20mA 16 bit A-to-D Conversion Field Selectable Definition



← **Insertion Analyzer**  
Group Line Testing  
 Pipelines  
 Well Testing  
 Emulsion Interface Control



↑ **Flow-Through**  
 Group Line Testing  
 Pipelines  
Well Testing  
 Emulsion Interface Control

**Flow-Through** →  
 Group Line Testing  
Pipelines  
 Well Testing  
 Emulsion Interface Control

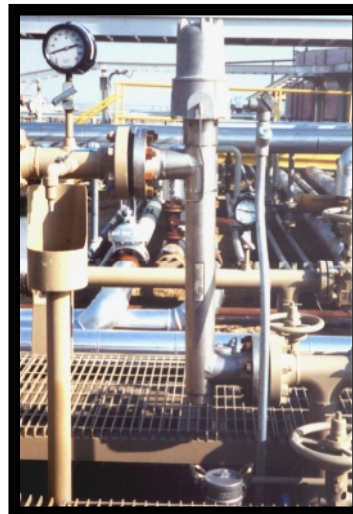

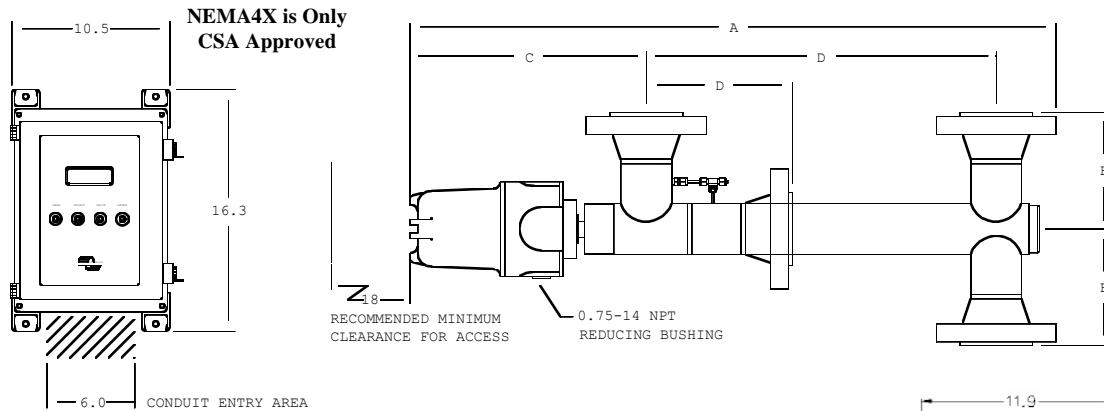

**Figure 2**

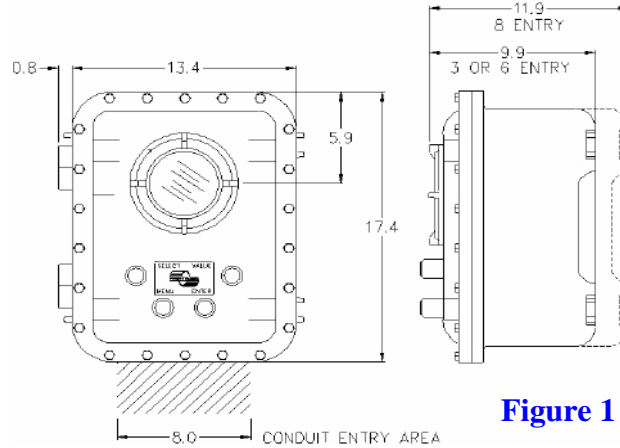
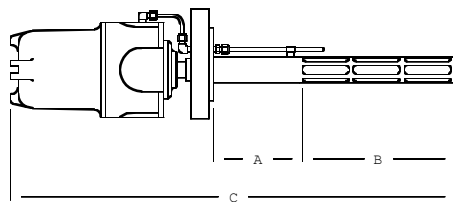

**Figure 1**

**Water Cut Analyzer Measurement Section Dimensions**

Nominal Pipe Size	Configuration "U", "Z", "L" or Insertion (Note 1)	Flange Size (Note 2)	Dimensions Inches				Net Weight lbs.
			A	B	C	D	
1 inch	U & Z	150	39.7	5.1	13.3	24	28
"	U & Z	300	39.7	5.4	13.3	24	31
"	U & Z	600	39.7	5.7	13.3	24	31
"	U & Z	900	39.7	6.3	13.3	24	36
2 inch	U & Z	150	41.8	6.0	14.8	24	52
"	U & Z	300	41.8	6.3	14.8	24	56
"	U & Z	600	41.8	6.6	14.8	24	60
"	U & Z	900	41.8	8.0	14.8	24	72
"	L	150	----	6.2	15	10	36
"	L	300	----	6.5	15	10	40
"	L	600	----	6.8	15	10	44
"	L	900	----	8.0	15	10	56
3 inch	U & Z	150	44.0	7.3	16.2	24	78
"	U & Z	300	43.3	7.6	16.2	24	91
"	U & Z	600	43.3	8.0	16.2	24	91
"	U & Z	900	43.3	8.8	16.2	24	113

Nominal Pipe Size or Type	Configuration "U", "Z", "L" or Insertion (Note 1 & 4)	Flange Size (Note 2)	Dimensions Inches				Net Weight lbs.
			A	B	C	D	
3 inch	L	150	----	7.25	16.2	10	52
"	L	300	----	7.6	16.2	10	60
"	L	600	----	8	16.2	10	60
"	L	900	----	8.8	16.2	10	82
Low Cut	Insertion	150	6.1	5.8	25.8	----	26
Low Cut	Insertion	300 / 600	6.1	5.8	25.8	----	28
Mid/Full/H	Insertion	150	6.1	10.5	30.5	----	37
Mid/Full/H	Insertion	300 / 600	6.1	10.5	30.5	----	39
4 inch	U & Z	150	33.2	8.5	16.7	12	120
"	U & Z	300	33.7	8.9	16.7	12	140
"	U & Z	600	34.1	9.8	16.7	12	150
"	U & Z	900	34.4	10.3	16.7	12	178
"	L	150	----	8.5	16.1	10	67
"	L	300	----	8.9	16.1	10	87
"	L	600	----	9.75	16.1	10	108
"	L	900	----	10.25	16.1	10	136

Notes:

1. Consult Factory for configurations including High Temperature versions
2. Flanges are dimensioned as ANSI Raised Face. Higher pressure rating flanges and RTJ flanges are available – consult Factory for dimensions and availability
3. Mid Range, Full Range and High Range are not available in 1" pipe
4. Insertion units have different lengths depending upon water cut measurement range. The Low Range has different dimensions from Mid, Full or High Range analyzers. All have 3" flanges.

